

EECE 2412 – Homework 3 – Spring 2017

Due: Thursday, February 9, 2017

- 1) Use the ideal diode model to determine the labeled voltages and currents in the circuits below.

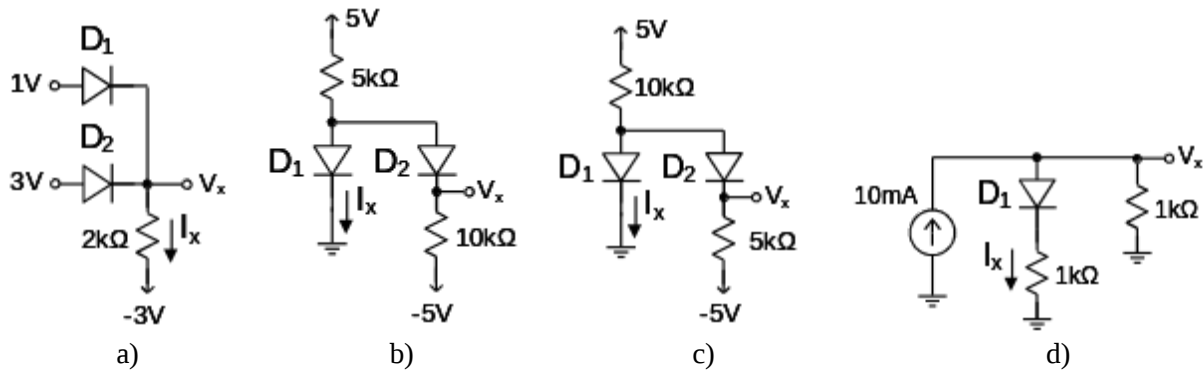

- 2) Repeat the analyses of the circuits in problem 1, but use the constant voltage drop (CVD) model with a voltage drop of 0.7V for forward-biased diodes.
- 3) Problem 3.10 on page 190 in the textbook, but with an extra part:
 b) For the case with a 1V source, assume that the diode has the device characteristics (i vs. v) shown in Figure P3.9(d) on page 190. Use load-line analysis to estimate the diode current (i_d) and voltage (v_d).

- 4) Read Section 3.8 of the textbook before solving this problem. The measured values of a diode at a junction temperature of 27°C are given by

$$V_D = 0.5V \text{ at } I_D = 5\mu A$$

$$V_D = 0.6V \text{ at } I_D = 100\mu A$$

Assume that $I_D/I_S \gg 1$.

- a. Determine the emission coefficient (n) of the diode.
 - b. Find the saturation current (I_S) of the diode.
- 5) Source V1 is the input voltage of the circuit shown below, and the output voltage is taken at the node labeled “Out”.
- a. Assuming a constant voltage drop diode model (with a 0.7V drop when diodes are forward-biased), find the output voltage V_o (at node “Out”) with V1 = 5V using hand calculations.
 - b. Simulate the circuit in PSpice to verify your results from parts a) using the “Dbreak” diode model in the PSpice library. Make sure that all DC voltages and currents that result from V1 = 5V are displayed in the schematic before you print it out for submission.
 - c. Determination of the transfer characteristics: Perform a DC sweep of V1 from -5V to 15V with 0.01V increments to plot V_o vs. V1. Before printing the plot for submission with the homework, place labels at the voltage levels where the diodes turn on or off.

